

Detail of CMS600 System

Model: CMS600
Manufacture: Fox Environmental Systems
Max Working Pressure: 170 PSI
Grate Class: Class D Heavy Duty
RPZ: Compliant with ASSE1013

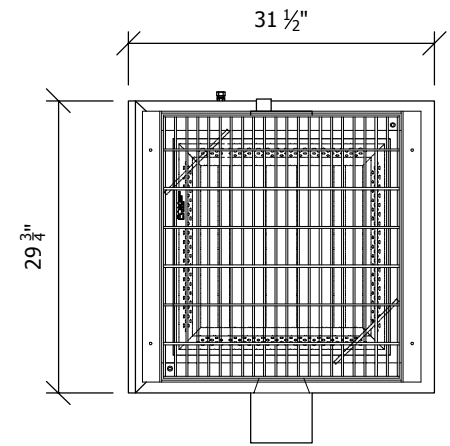

Plan View

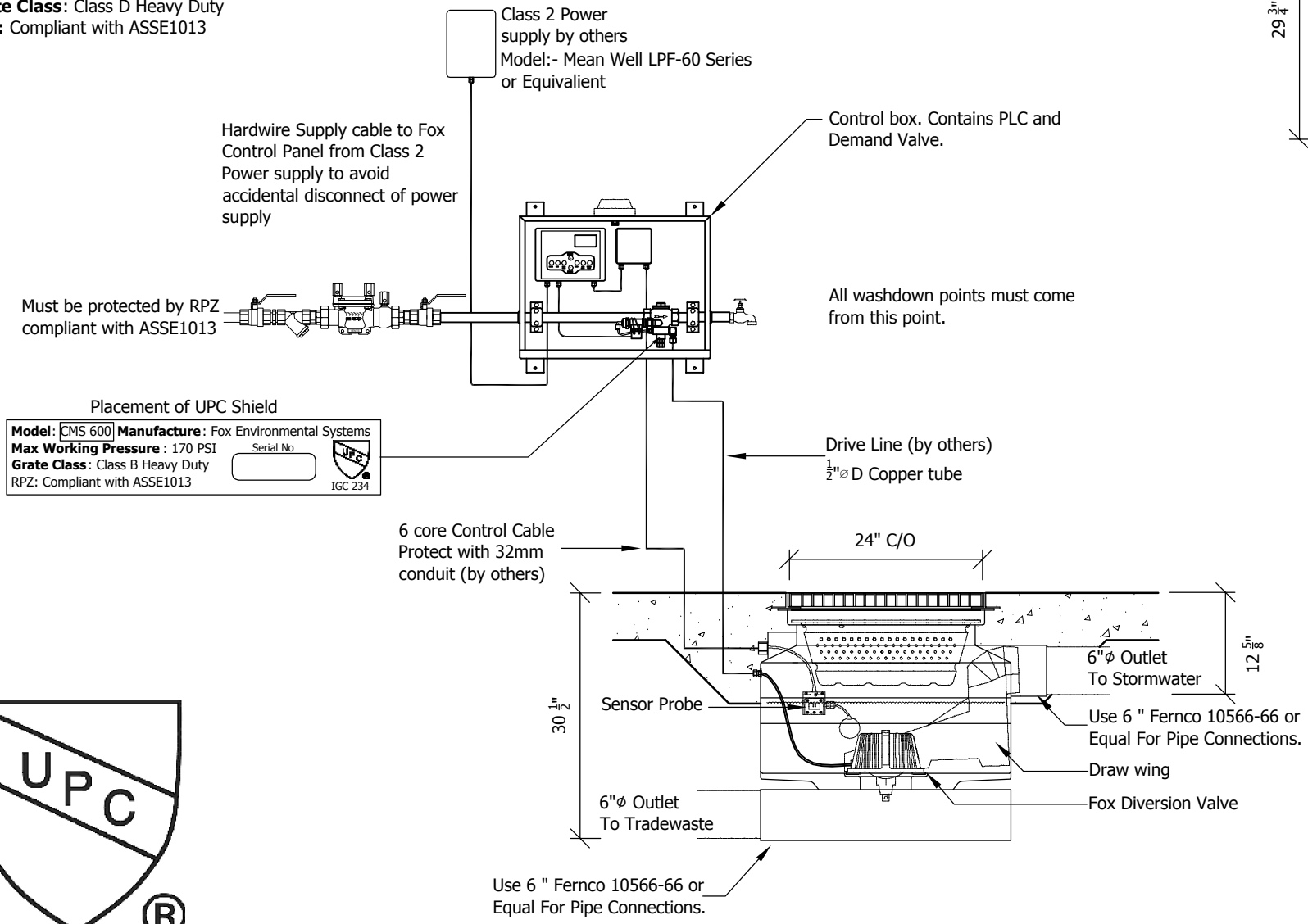

Must be protected by RPZ compliant with ASSE1013

Hardwire Supply cable to Fox Control Panel from Class 2 Power supply to avoid accidental disconnect of power supply

Class 2 Power supply by others
 Model:- Mean Well LPF-60 Series or Equivalent

Control box. Contains PLC and Demand Valve.

All washdown points must come from this point.

Placement of UPC Shield

Model: CMS 600 Manufacture: Fox Environmental Systems
 Max Working Pressure : 170 PSI
 Grate Class : Class B Heavy Duty
 RPZ: Compliant with ASSE1013

Serial No.



6 core Control Cable Protect with 32mm conduit (by others)

Drive Line (by others)
 1/2" Ø D Copper tube

24" C/O

30 1/2"

12 5/8"

Use 6 " Fernco 10566-66 or Equal For Pipe Connections.

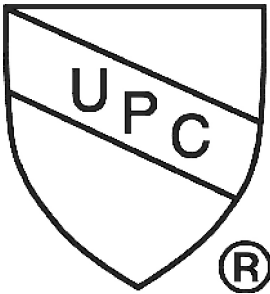

IAPMO IGC 234 2016
 File Number 10153



Project
IAPMO

Drawing Title
CMS600 System

Drawn by:	J.F.S
Date:	15/08/2016
Scale:	1:20
Drawing No:	A4-SPEC-1011